

Plain Paper Copier

FP-7713/7715

Options for FP-7715
Paper Feed Console (FA-DS16)
ADF (FA-A502)

Operating Guide

2

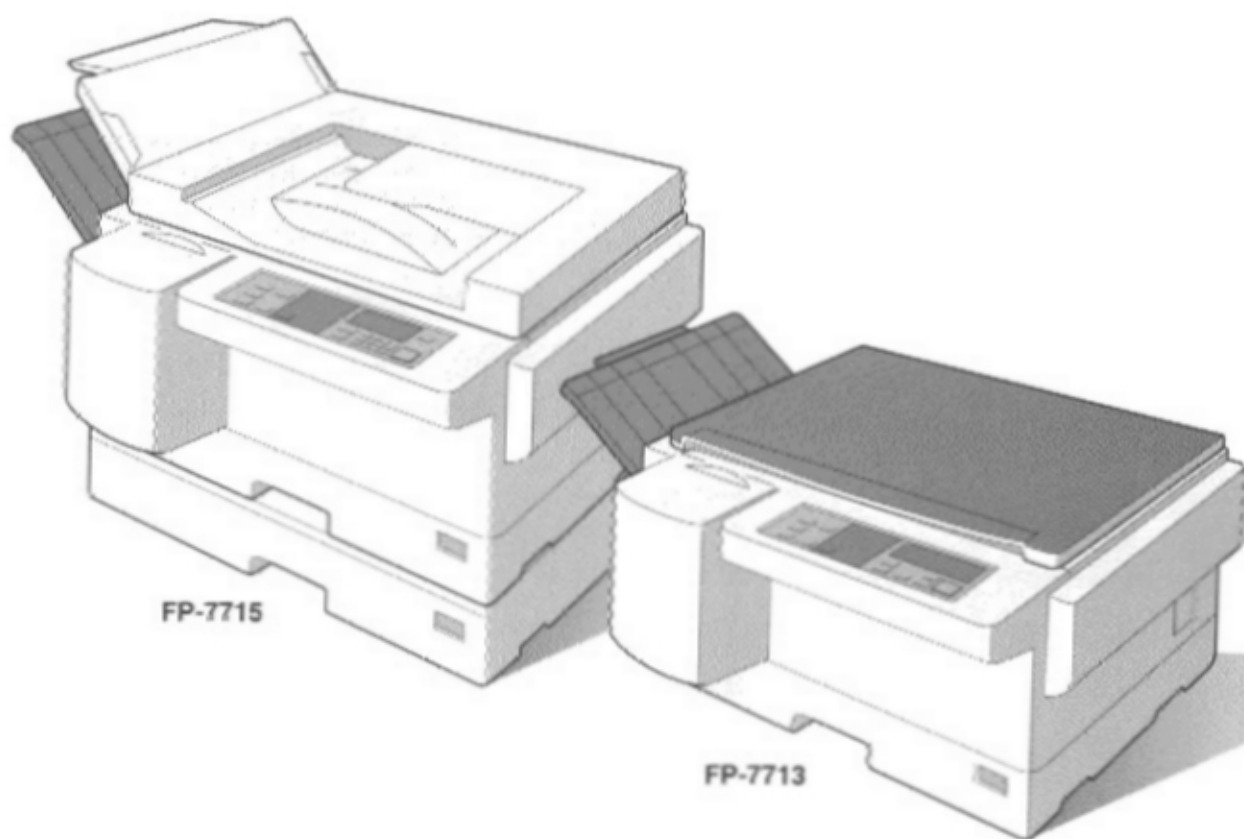

FP-7715

FP-7713

Before operating this copier, please read these instructions completely and keep this operating guide for future reference.

The FP-7713/7715 with options
(See page 4)

Making Copies

Full Size Copying 100%

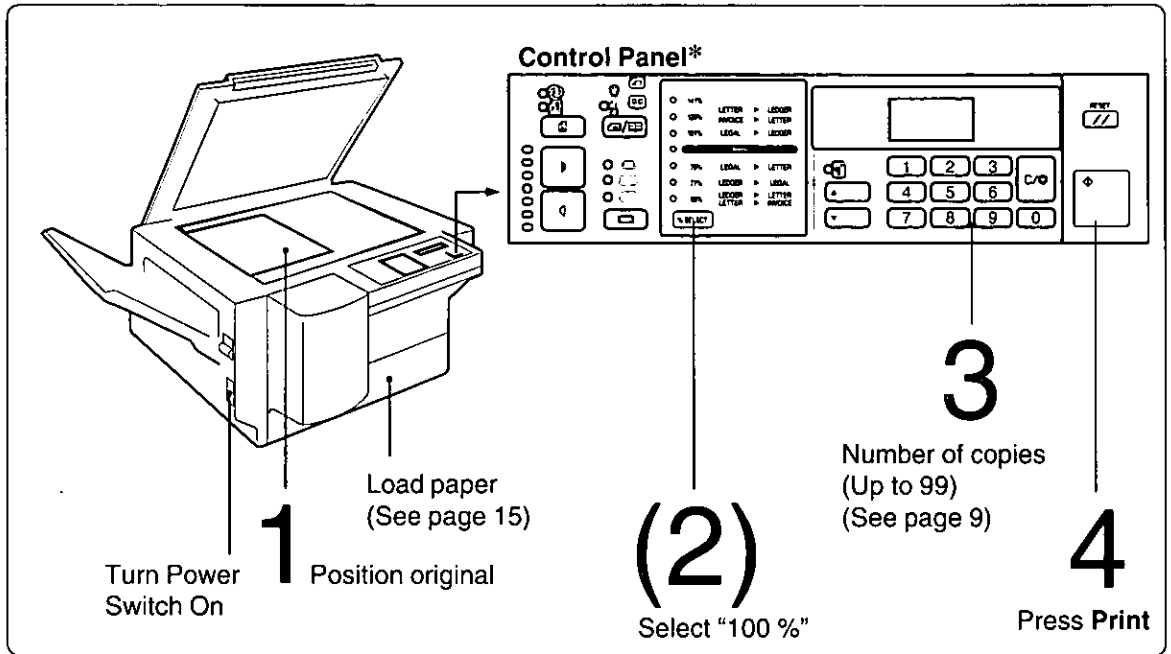

* NOTE: In this manual operating instructions are described using the FP-7715 control panel. Differences between the FP-7715 and FP-7713 control panels are indicated on pages 8 and 9.

Position of the original

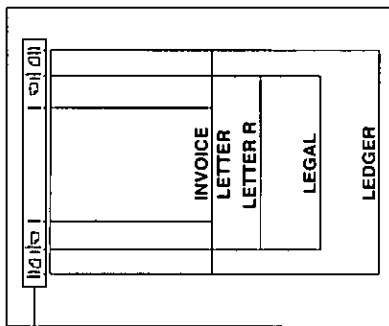

Original Guide

- Place original against guide.

- Face DOWN on platen.
- If the original is not positioned properly, a portion of the original may not be copied.
- When copying on letterhead, position sheets in sheet bypass face down.

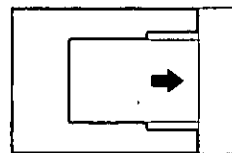

Copy side down

- See page 19 for ADF operation.



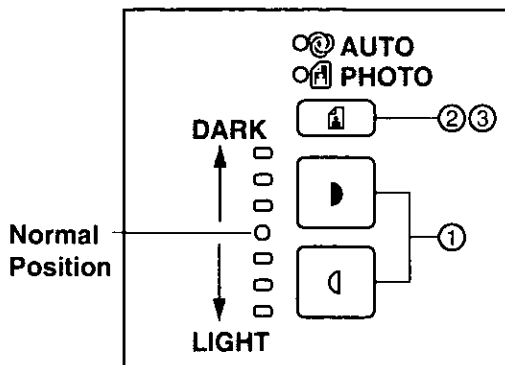

Selecting exposure control:













- ① Press the Light key to copy colored background or Dark key for light image original etc.,
- ② Press the Auto/Photo Select key to copy photos and halftones.
- ③ **When selecting Auto mode**
Press the Auto/Photo Select key to copy with Auto exposure control (Ⓜ).

Creative Features/Symbol Marks

■ Creative Features

	Reduction or Enlargement	(See page 10)	When copying with preset ratios
	Zoom	(See page 11)	When copying with variable zoom ratios
	2-Page Copy	(See page 12)	Copies facing pages (i.e. book or magazine) onto separate sheets.
	Sky Shot	(See page 13)	Dark areas can be eliminated when copying with the platen cover/ADF open.

■ Symbol Marks

	Wait		Wait until the copier warms up.
	Add Paper		<ol style="list-style-type: none"> ① Add paper if paper drawer/tray or sheet bypass is empty. (See page 14, 15) ② When using ADF: A selected paper size is not stocked in the Paper Drawer/Tray, use the Sheet Bypass. (See page 14)
	Add Toner		Add toner then press any key on control panel. (See page 17)
	Paper Misfeed		Remove misfed paper. (See page 18, 20)
	(ADF/Option)		
	Service Call		Lights up when it's time for routine maintenance.

Options/Functions

■ Options

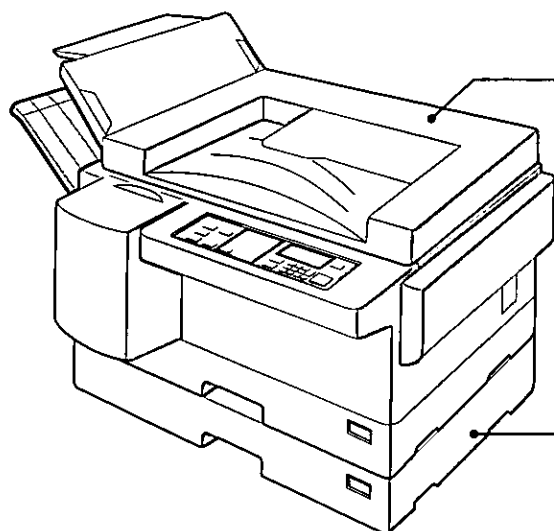

ADF, Automatic Document Feeder

(FA-A502/FP-7715)

- To feed originals automatically.

Paper Feed Console

(FA-DS16/FP-7715)

- To increase paper feed source.

■ Power Saving Mode

The FP-7713/7715 has a function for power saving while the copier is not in use. If you wish to use this feature, consult your service technician.

	Power Consumption	Warm Up Time
Normal Operation	Approximately 100 Wh	None
Stand-by mode	Approximately 45 Wh	15 Seconds
Power Saving mode	Approximately 9 Wh	40 Seconds

■ Auto Start function

While the copier is warming up, you may position your original on the copier, enter your copy job selections and press the Print key. The wait indicator will flash until the warm up cycle is completed and the copy job will automatically start.

Table of Contents

Before operating

Precautions		6
Components	■ Control Panel	8

Making Copies

Common Features	■ Full Size Copying	2
	■ Reduction or Enlargement Copying	10
	■ Zoom Copying	11
Creative Features	■ 2-Page Copy Mode	12
	■ Sky Shot Mode	13
	■ Using the Sheet Bypass	14

Maintenance

Handling	■ Adding Paper	15
	■ Changing Paper Size	16
	■ Adding Toner	17
	■ Removing a Paper Misfeed	18

Options

■ Usage	19
■ Removing a Paper Misfeed	20

Specifications

FP-7713/7715/FA-A502/FA-DS16	21
------------------------------	----

Checking

Troubleshooting	22
Care of Copier	24

Precautions

Handling

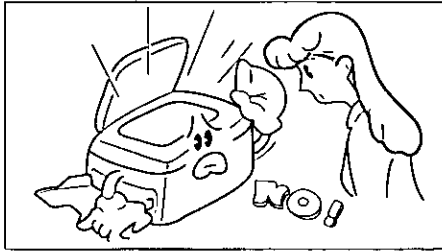

- Do not look directly at exposure lamp when copying.

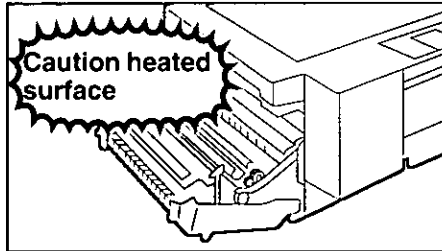

- Use caution not to touch the heated area when checking inside the copier.

- If the copier makes irregular sounds or emits an abnormal odor, turn the power switch off and contact your authorized Panasonic dealer for service.

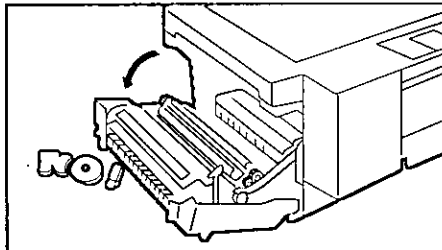

- Do not turn the power switch OFF or open the left cover during copying.

- Do not drop paper clips, staples or other metal objects into the copier.

- Do not attempt to remove any cover (except as described in this operating guide).

Toner and Paper

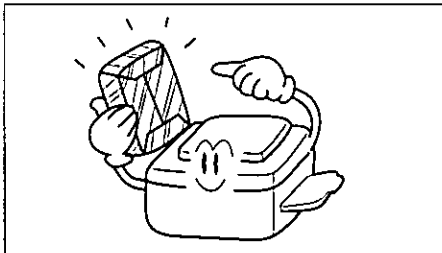

- Store toner, developer and paper in cool areas with low humidity.
- High quality paper of 16 lbs. - 24 lbs. (15 - 34 lbs. via sheet bypass) may be used.
- For optimum performance, it is recommended that only Panasonic Brand supplies be used in the copier.

Installation

- The copier should not be installed in areas with the following conditions:
 - Extremely high or low temperature and humidity.
Ambient conditions
Temperature: 50°F - 86°F
Relative humidity: 30% - 80%
 - Where temperature and humidity can change rapidly, causing condensation.
 - Direct exposure to sunlight.
 - Directly in air conditioning flow.
 - In areas of high dust concentration.
 - In areas of poor ventilation.
 - In areas with chemical fume concentration.
 - In areas with extreme vibration.
 - With unstable or uneven conditions (floors, etc.).

Installation

- The FP-7713/7715 power consumption is 1.35 kW.
A properly wired (with ground), dedicated, 15A, 120V AC outlet is required. Do not use an extension cord.

Ventilation

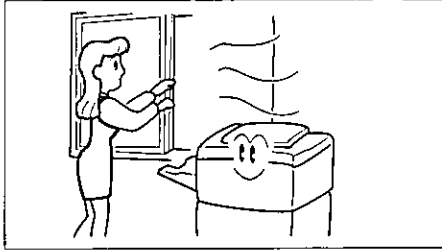

- The copier should be installed in a well-ventilated area to minimize the ozone density in the air.

For U.S.A.

This equipment has been tested and found to comply with the limits for a Class A digital device, pursuant to part 15 of the FCC Rules. These limits are designed to provide reasonable protection against harmful interference when the equipment is operated in a commercial environment. This equipment generates, uses, and can radiate radio frequency energy and, if not installed and used in accordance with the instruction manual, may cause harmful interference to radio communications. Operation of this equipment in a residential area is likely to cause harmful interference in which case the user will be required to correct the interference at his/her own expense.

Any unauthorized changes or modifications to this equipment would void the users authority to operate this device.

Components

Control Panel

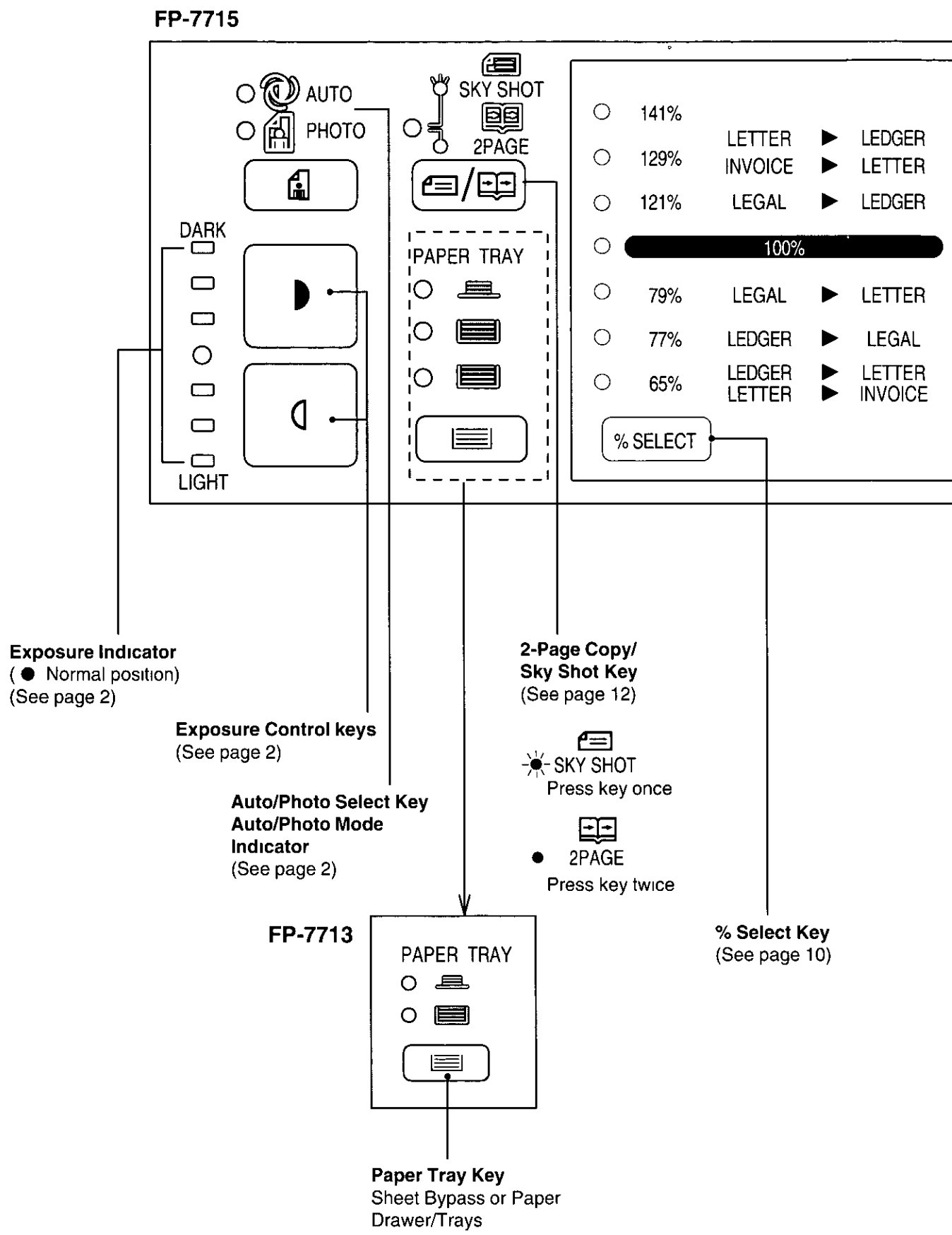

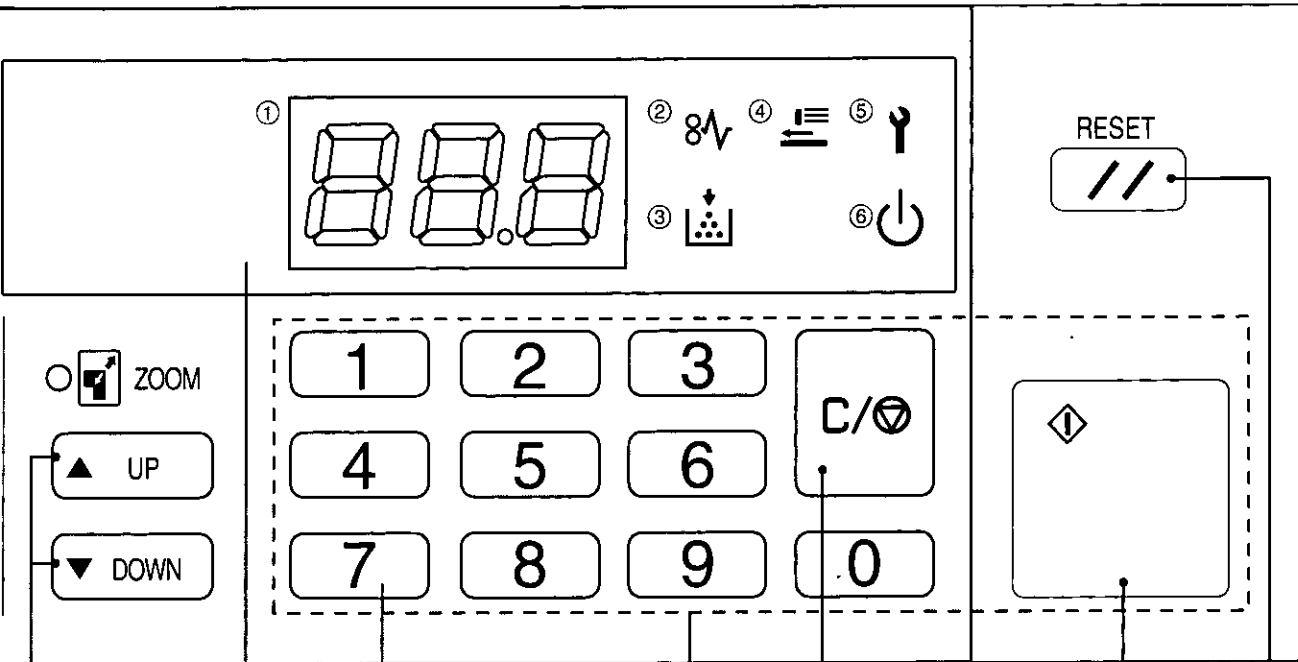

Zoom Keys
(See page 11)

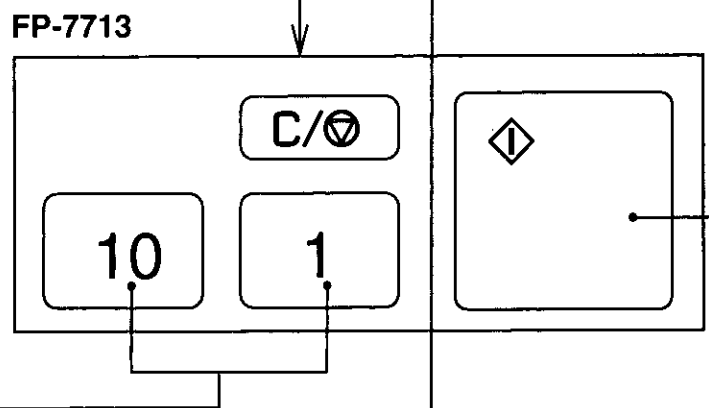

Quantity Keys

Print Key

Communications Monitor

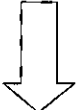

Clear/Stop Key
Press to stop copy run or clear copy count in display.

Reset Key (FP-7715)
Press to reset all features to initial power-on state.

① **Copy Count Display**
Indicates number of copies and error code etc. (See page 22)
②~③, ④ (FP-7715), ⑤~⑥
(See page 3)

Reduction or Enlargement Copying

When copying with preset ratios

- There are 3 preset reduction and 3 preset enlargement modes.

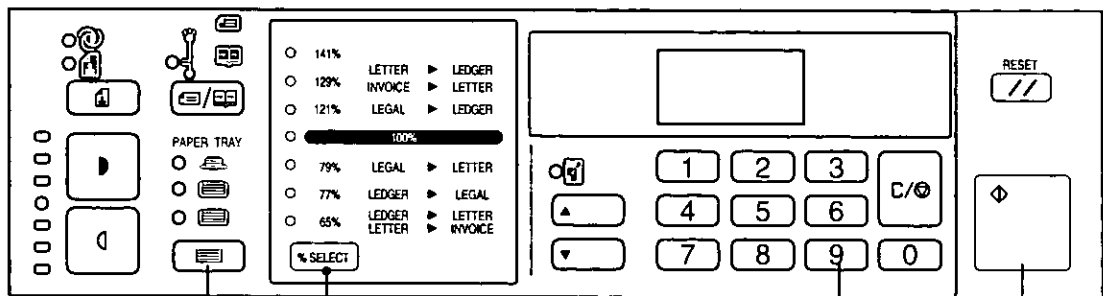

- 1 Paper Tray Key***
Position original
- 2**
Select the copy ratio/size
(Landscape for letter size)
- 3**
Number of copies
- 4**
Press **Print**

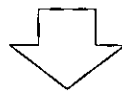

% Select Key

Example: Reduction

Original size Copy size

LEDGER

→

LETTER

The correct ratio is automatically selected.

- When feeding original(s) from ADF, see instructions on page 19.
- To reset reduction or enlargement copying, press Reset key. (FP-7715)

NOTE

* When copy size is different from paper size of paper drawer/tray, use sheet bypass. (See page 14)

● To change paper size of the paper drawer/tray, see page 16.

Zoom Copying

When copying with variable zoom ratios

- A zoom ratio can be selected from 65% to 141% in 1% increments.

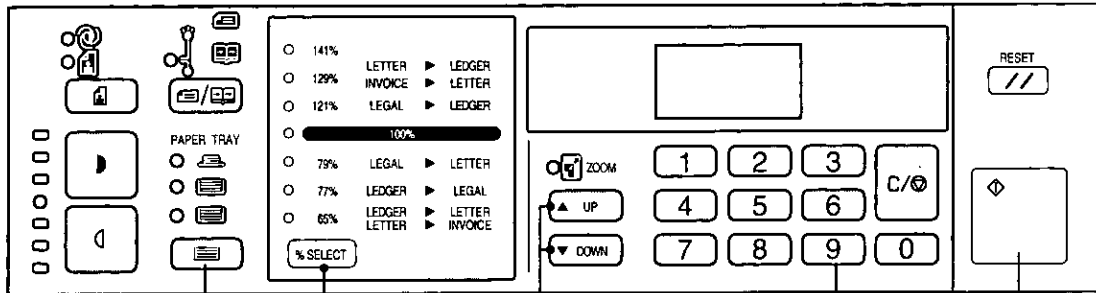

- 1** Paper Tray Key* % Select Key
Position original
- 2** Select zoom ratio
- 3** Number of copies
- 4** Press Print

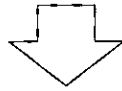

- ① Press UP or DOWN key.
- ② Select zoom ratio.

Zoom Ratio: 65% – 141%

Press and hold the Zoom Down or Zoom Up key.

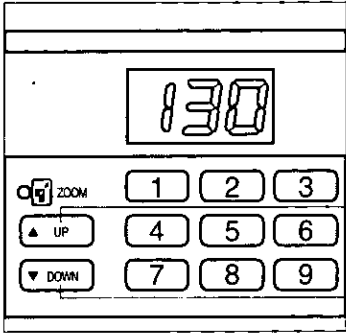

UP For enlargement

DOWN For reduction

Increase/decrease in 1% increments.

- To reset zoom copying, press Reset key. (FP-7715)

NOTE

* When copy size is different from paper size of paper drawer/tray, use sheet bypass. (See page 14)

- To change paper size of the paper drawer/tray, see page 16.

2-Page Copy

- Copying two facing pages of a ledger size original on two separate letter size sheets.

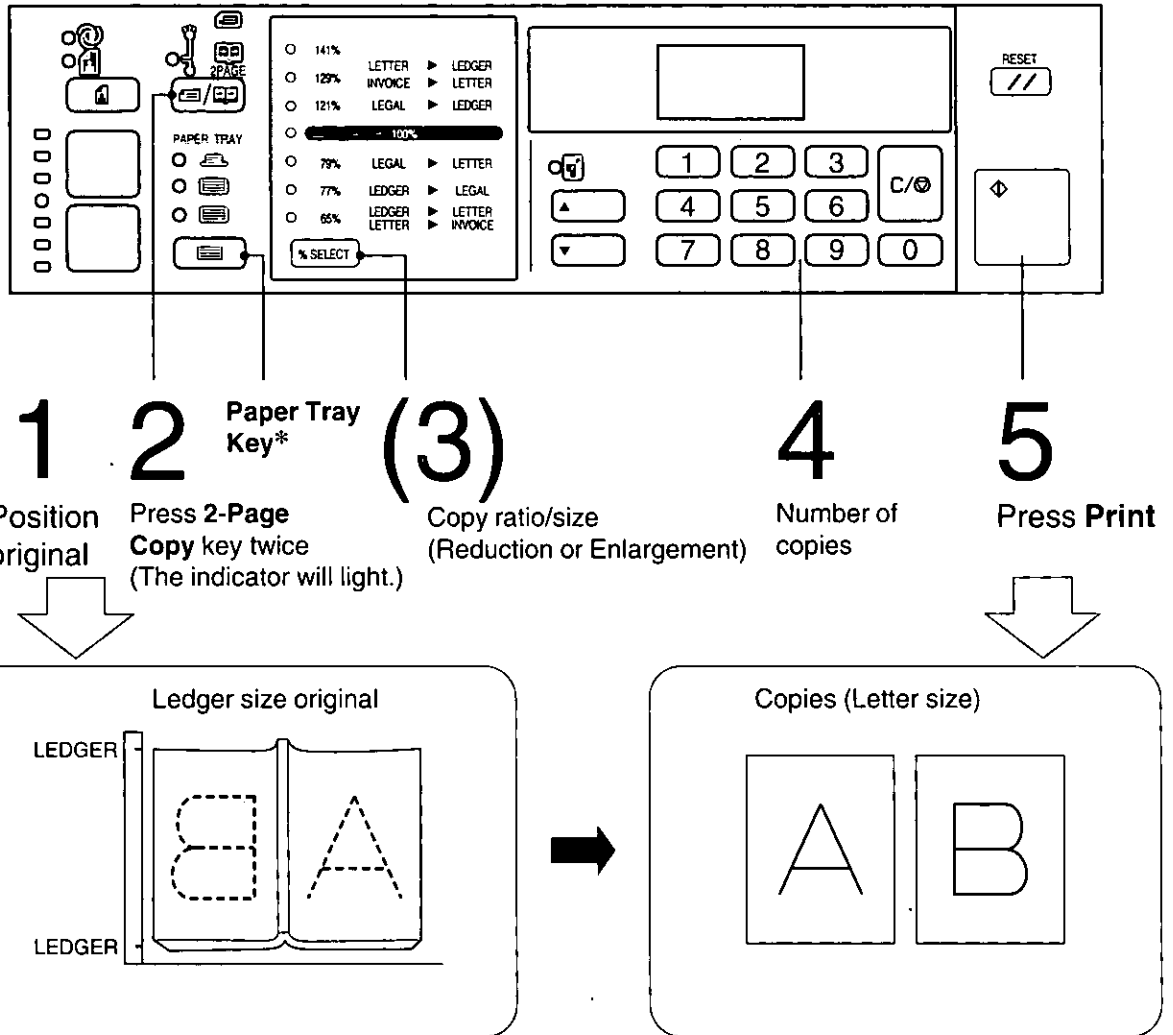

- To reset 2-page copy, press 2-page key again, or press Reset key (FP-7715).

NOTE

* When copy size is different from paper size of paper drawer/tray, use sheet bypass. (See page 14)

- To change paper size of the paper drawer/tray, see page 16.

Sky Shot Mode

- By setting the check size (or other specific original size), copying from originals is possible without dark areas around the image.

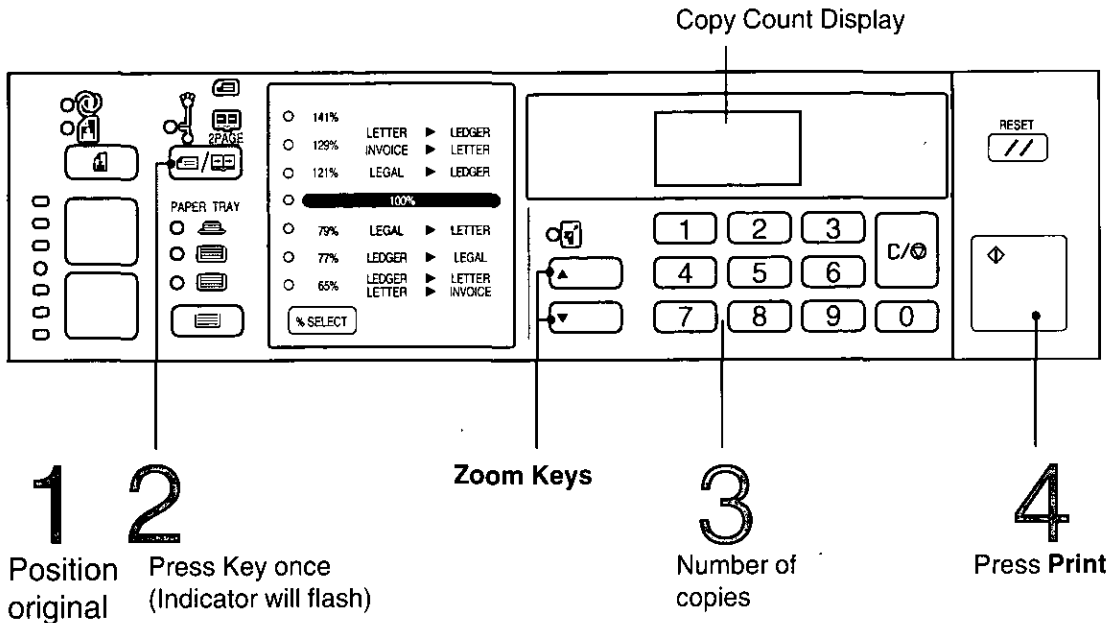

■ Setting the original size

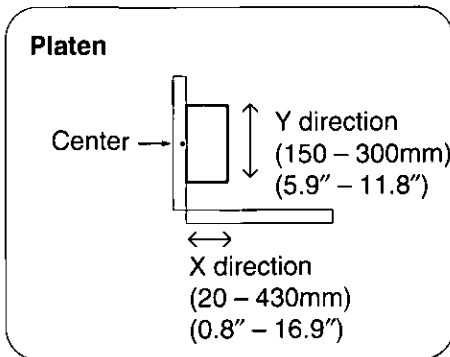

- When setting or changing an original size, follow the procedures to the right. Then make copies following the steps above.

1. Press and hold Sky Shot key. (More than two seconds)
2. Y direction will appear in the Copy Count Display. (Three seconds)
3. Input a Y direction size with Zoom Up/Down key. (In 10mm increment)
4. Press **Print**.
5. X direction will appear in the Copy Count Display. (Three seconds)
6. Input an X direction size with Zoom Up/Down key. (In 5mm increment)
7. Press **Print**.
Above X/Y sizes will be memorized.

NOTE

- To reset Sky Shot mode, press Sky Shot key twice, or press Reset key (FP-7715).

2-Page Copy Sky Shot Mode

Using the Sheet Bypass

When copying on special paper, etc.

- For 2-sided copying or to copy on letterhead, mailing labels, transparencies and odd-size paper, etc., or to use bypass as an additional paper source.

1

Position original.
Select copy ratio/size.

2

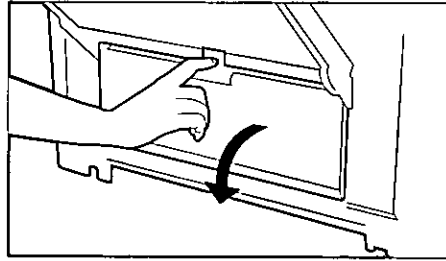

Open sheet bypass.

3

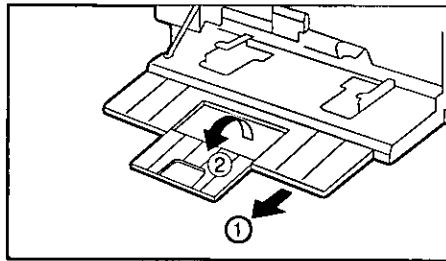

- ① Pull out tray 1 until it stops.
- ② Open the tray 2.
(Letter R, legal and ledger size)

4

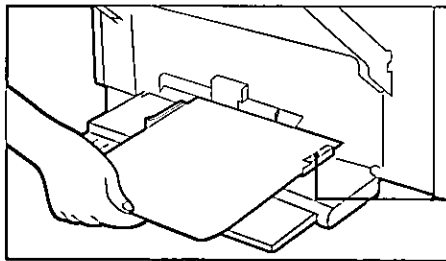

- ① Place approximately 50 sheets of paper into the tray.

Insert the paper until it stops.



Copy side down for copying on letterhead paper and mailing labels.

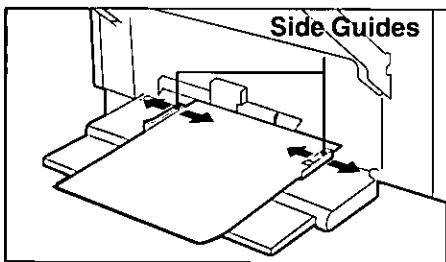

- ② Adjust the side guides.

Incorrect adjustment may cause paper to wrinkle, misfeed or skew.

5

Select sheet bypass with Paper Tray key. (FP-7713)

Press Print.

NOTE

- When making 2-sided copies, use the sheet bypass.
- The bypass has priority over the paper drawers/trays. The copier automatically selects the sheet bypass when paper is placed in the empty bypass tray. (FP-7715)

Adding Paper (P)

250 Sheet Paper Drawer/Tray

■ The following steps are an example of the Add Paper Procedure and are applicable for the optional 250 sheet paper drawer.

1

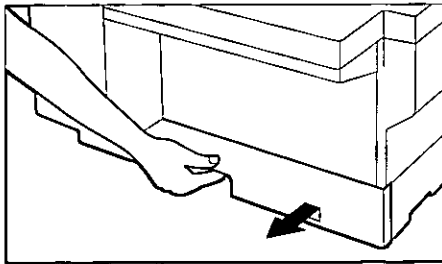

Pull paper drawer/tray out of copier.

2

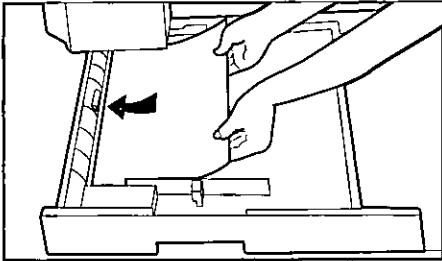

Place paper into paper drawer/tray.

For better feeding, remove any wrinkled or torn sheets.

Note:

When copying on 16 lb paper, use the sheet bypass.

3

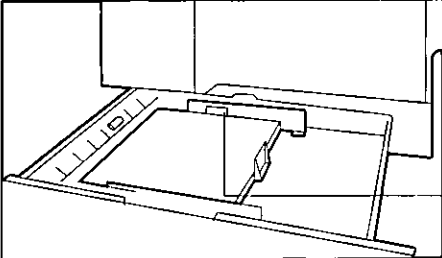

Make sure paper is not loaded above overfill indicator located in the paper drawer/tray.

Overfill Indicator

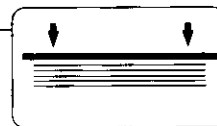

← 1-sided copy

4

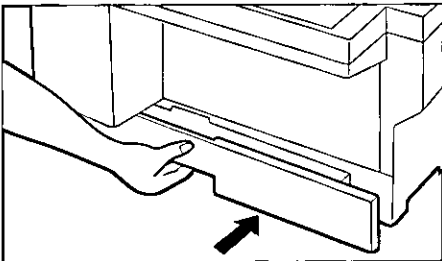

Push paper drawer/tray back into copier.

NOTE

- The paper drawer/tray is designed to accommodate invoice, letter, letter R, legal and ledger size paper. (FP-7715) To change the paper size, consult your service technician for proper instructions.
- When making 2-sided copies, use the sheet bypass.
- When using the optional 250 sheet paper drawer (FA-DS16), do not pull paper drawer/tray out of copier.

Changing Paper Size

FP-7715

■ The paper drawer/trays are designed to accommodate invoice, letter, letter R, legal and ledger size paper. To change the paper size, consult your service technician for proper instructions.

Perform following steps as shown below only after any locking screws have been removed.

3 Check paper size
(See table below)

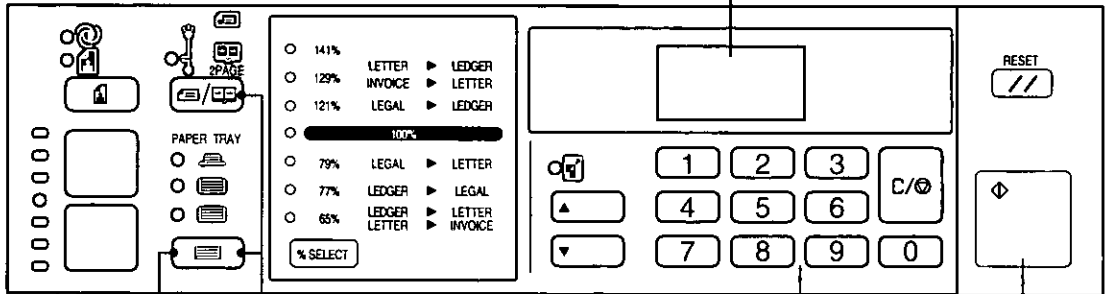

(2)
Select paper drawer/tray*

1
Press 2-page key while pressing paper tray key

1: Ledger
2: Legal
3: Letter
4: Letter R
5: Invoice

4
Select paper size
(See left table)

5
Press Print

6

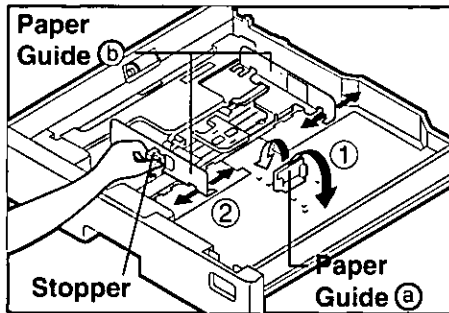

Pull out the desired paper drawer/tray.

- ① Adjust paper guide (a) to paper length.
- ② Adjust paper guide (b) to paper width. Squeeze the stopper to move the paper guide (b) to the desired paper size.

7

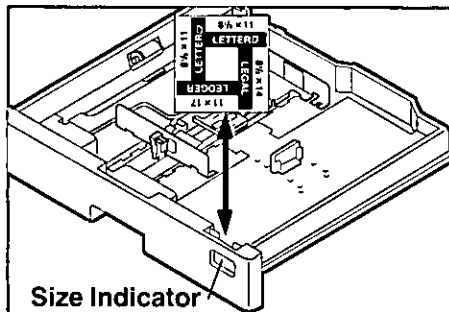

Change the paper size indicator.

Take out and re-insert the indicator so the correct paper size is shown. (Invoice size is on the back side)

NOTE

* FP-7715 with FA-DS16 (option) only.

- Some key operators may not want casual users to have the ability to change the paper size. Therefore, the "Paper size change" setting may be set to "Unadjustable" by a service technician. Consult your service technician.

Adding Toner (L3) (U3)

1

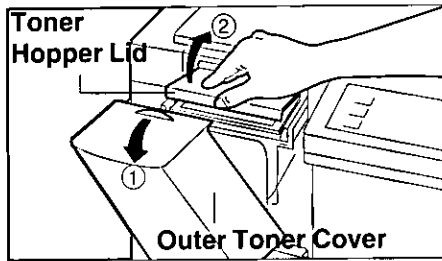

Open the outer toner cover and toner hopper lid.

2

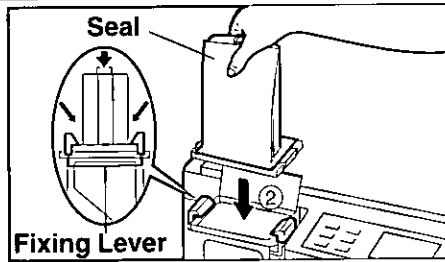

Install the toner cartridge.

- ① Shake well before using. 10–15 times until the toner inside is evenly distributed.
- ② Position the toner cartridge to fixing lever and push down the cartridge.

3

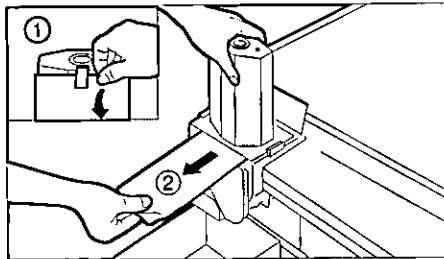

Add toner.

- ① Pull off the seal.
- ② Gently pull out the seal.

4

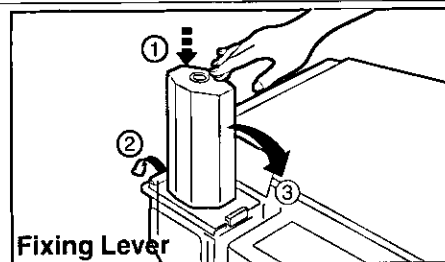

Remove the toner cartridge.

- ① Tap the toner cartridge.
- ② Pull the fixing lever.
- ③ Remove the toner cartridge.
- ④ Close the toner hopper lid.

5

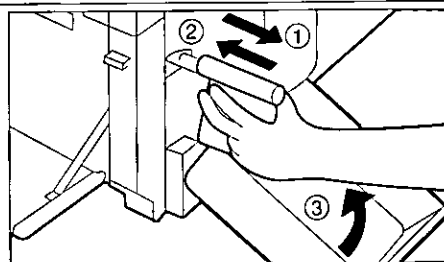

Replace the waste toner bottle.

- ① Slowly pull waste toner bottle straight out.
- ② Install new bottle.
- ③ Close the outer toner cover.

6

Replace the cleaning pad.
(See page 23)

ATTENTION

- Use recommended Panasonic toner.
- Store toner in a cool dark place.
- Do not unseal toner before use.
- Do not use toner in waste toner bottle.

Removing a paper misfeed (8 \sqrt{v})

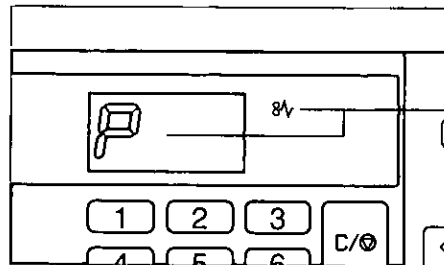

Paper Misfeed Indicator
(P: FP-7713)

- Before removing misfed paper, take paper out of the exit tray or sheet bypass.

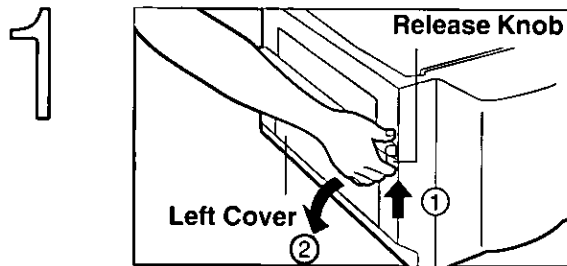

For Copier

- ① Hold release knob.
- ② Open the left cover slowly.
Close the sheet bypass, if the sheet bypass is opened.

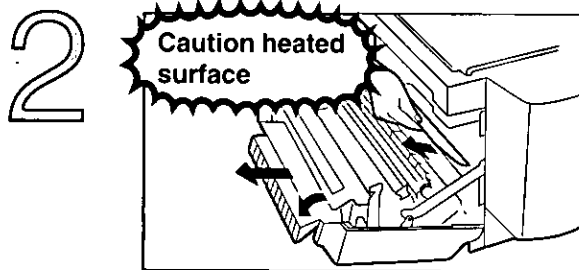

Remove all misfed paper.

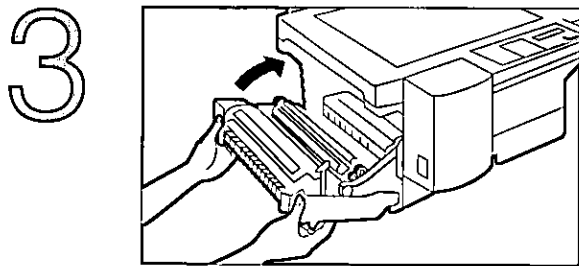

Close the left cover until it locks.

Use both hands.

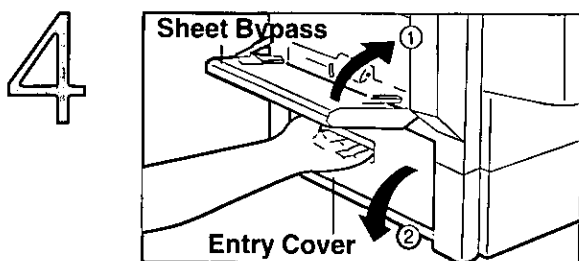

For FA-DS16 (Option)

- ① Close the sheet bypass, if the sheet bypass is opened.
- ② Open entry cover.
- ③ Remove misfed paper and close the entry cover.

ATTENTION

- The fusing area may be hot, so use caution when removing misfed paper.

Option

ADF (FA-A502)/FP-7715

1. Features

- ① Automatic original feeding.
 - The ADF tray can hold up to 50 originals of 20 lbs. paper. (30 originals/legal, ledger)
It can accommodate originals from letter to ledger size.
 - Automatic original size detection. (Except Invoice Size)
- ② Automatic paper selection (APS)
A paper drawer/tray is automatically selected according to copy size or ratio selected by the % Select key. (Original size: Letter, Letter R, Legal and Ledger)
- ③ Automatic magnification selection (AMS)
A copy ratio is automatically selected according to paper size of selected paper drawer/tray by the Paper Tray key. (Copy size: Invoice, Letter R, Legal and Ledger)

2. Components/Usage

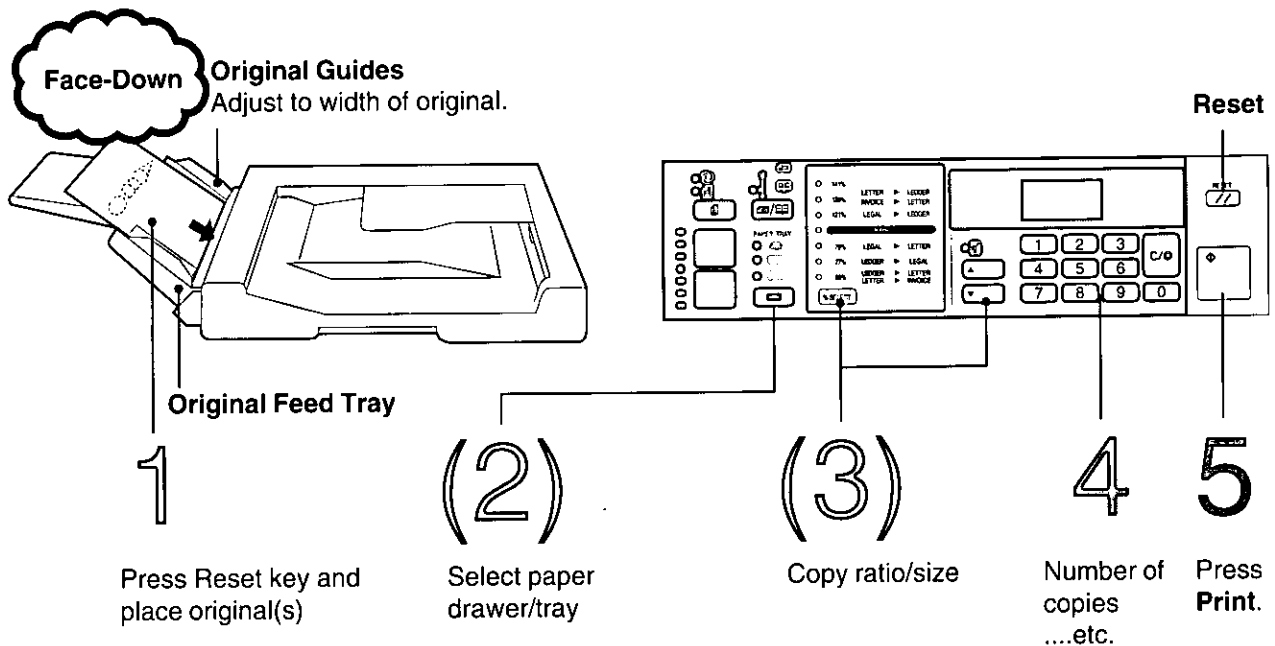

■ When using function "APS" or "AMS", operate according to following steps:

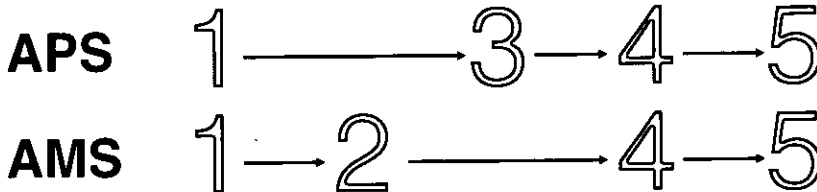

NOTE

Inappropriate originals

- Paper with a smooth surface such as glossy and coated papers
- Transparencies
- Paste-ups
- Originals with a lead edge that is "creased", "folded", "punched" or "glued"
- Pressure sensitive or carbon backed papers
- Paper with excessive curl
- Stapled originals



Removing a paper misfeed ()

When paper misfeed occurs in ADF/FP-7715

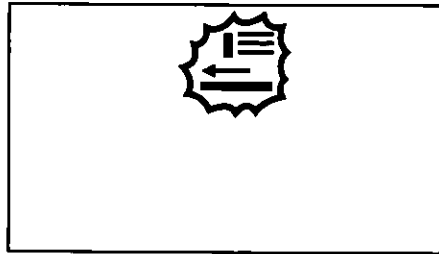

Symbol appears in the communications monitor.

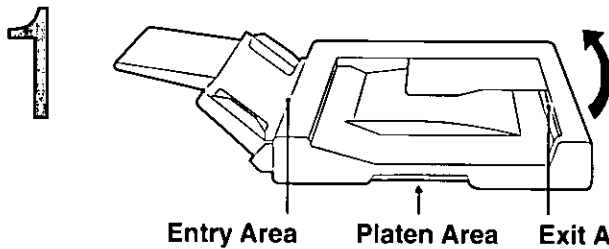

Open the ADF.

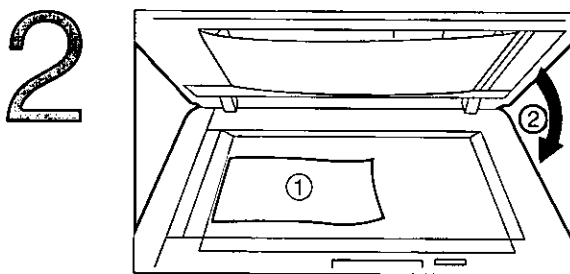

Platen Area

- ① Remove misfed paper.
- ② Close the ADF.

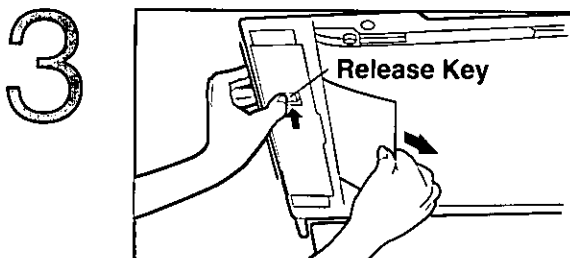

Entry Area

- ① Push the Release key and remove misfed paper.
- ② Close the ADF.

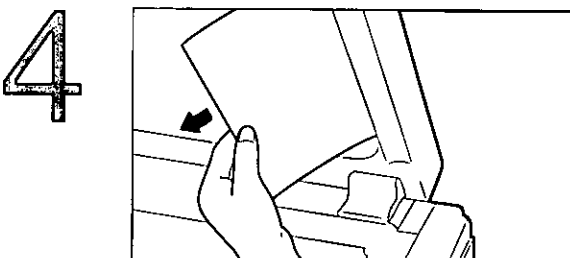

Exit Area

- ① Remove misfed paper.
- ② Close the ADF.

NOTE

- When using the ADF:
If the copier is stopped due to misfed paper or a "U13" error code, check the paper in the output tray and place the originals that have not been copied back in the document feeder and then press Start.
(U13, See page 17)

Specifications

■ FP-7713/7715

Type:	Desktop
Process:	SuperMagnefine™
Multi Copy Speed:	13 letter size copies per minute (FP-7713) 15 letter size copies per minute (FP-7715)
Maximum Copy Size:	11" × 17" (Ledger size)
Void Area:	Max. 5 mm for 1-sided copying
Copy Size:	Invoice, Letter, Letter R, Legal, Ledger via paper drawer/tray 5-1/2" × 8-1/2" — 11" × 17" via sheet bypass
Reduction Ratios:	Preset: 65%, 77%, 79% Variable: from 99% to 65% in 1% increments
Enlargement Ratios:	Preset: 121%, 129%, 141% Variable: from 101% to 141% in 1% increments
Paper Feed:	250 sheet paper tray plus 50 sheet bypass
Paper Selection:	Automatic (FP-7715)
Paper Weight:	20 – 24 lbs. (Paper drawer/tray) 16 – 34 lbs. (Sheet bypass)
Quantity Selector:	1 – 99, Automatic Repeat, Automatic Reset to 1
Exposure Control:	Automatic/Manual plus Photo Mode
Toner Supply:	Automatic
Dimensions:	24.8" (W) × 23.9" (D) × 13.7" (H) (FP-7713) 24.8" (W) × 24.8" (D) × 13.7" (H) (FP-7715)
Weight:	72.6 lbs.
Electrical Requirement:	AC 120V, 60Hz, 12 A

■ ADF (FA-A502), Paper Feed Console (FA-DS16) (Options for FP-7715)

	FA-A502	FA-DS16
Original/Paper Size:	Letter, Letter R, Legal, Ledger	Invoice, Letter, Letter R, Legal, Ledger
Original/Paper Weight:	16 – 26 lbs.	20 – 24 lbs.
Original/Paper Capacity:	50 sheets, 20 lbs./letter 30 sheets, 20 lbs./legal, ledger	Maximum 250 sheets, 20 lbs.
Electrical Requirements:	Supplied from copier	Supplied from copier
Dimensions:	22.8" (W) × 18.9" (D) × 3.7" (H)	22.4" (W) × 21.2" (D) × 5.4" (H)
Weight:	22.0 lbs.	15.4 lbs.

Specifications are subject to change without notice.



Troubleshooting

Before you call service

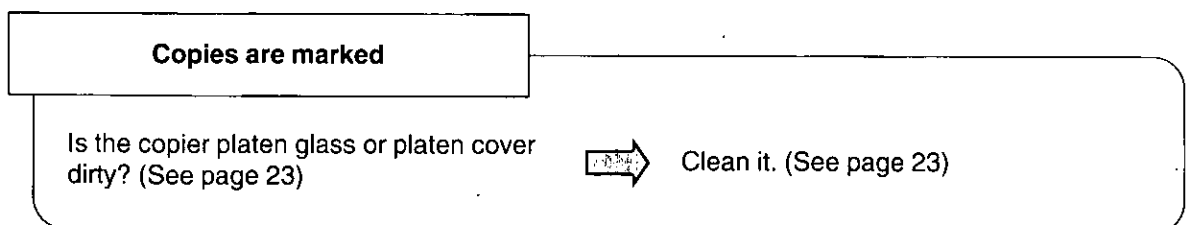
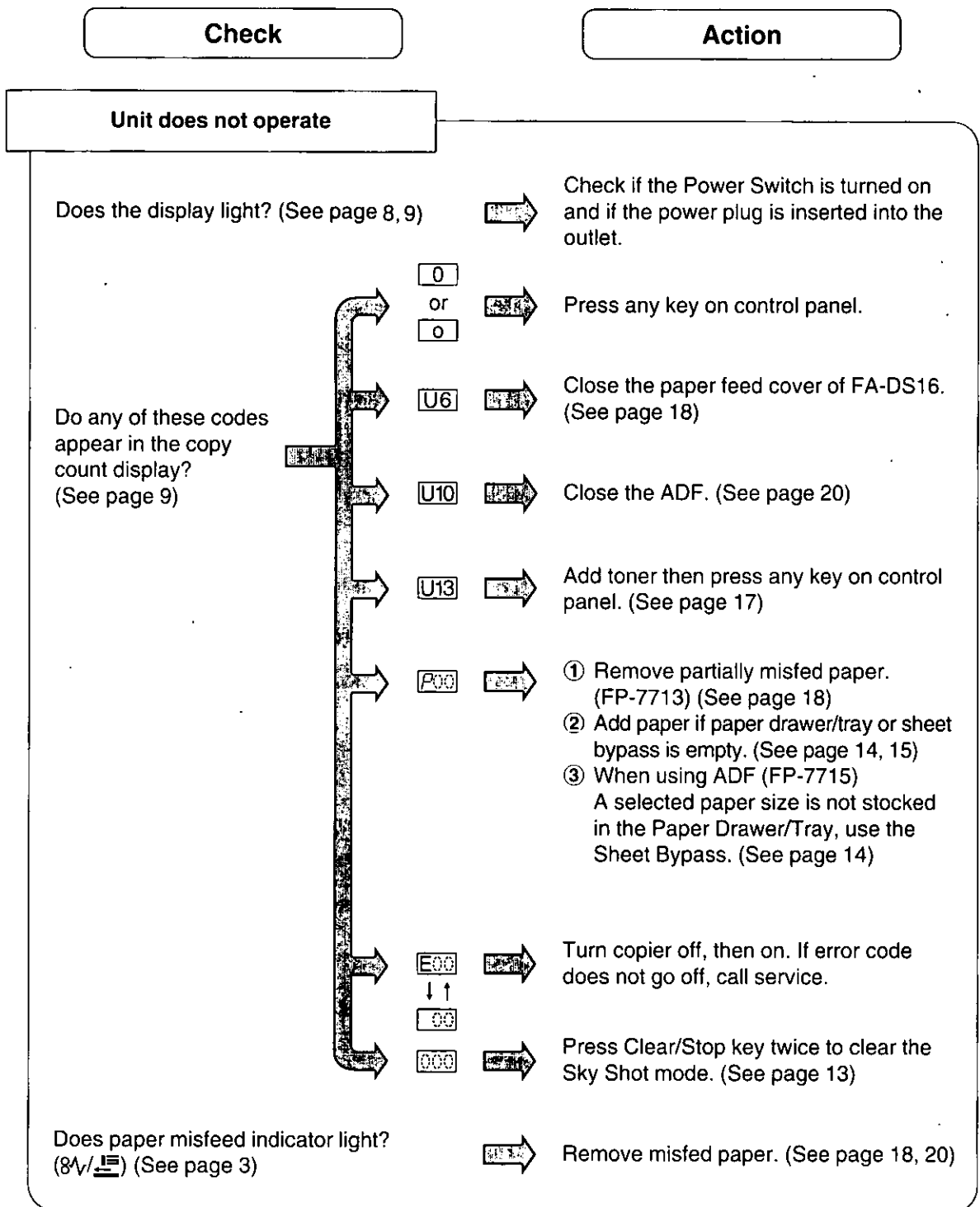

Check

Action

Copies are light

Does the exposure indicator say "light"?
(See page 2)



Press the Dark key. (See page 2)

Is the photo indicator on? (A)
(See page 2)



Press the Photo/Auto Select key (ⓐ)
once to choose the auto mode.
(See page 2)

Is the add toner indicator flashing? (T)
(See page 3)



Add toner then press any key on control
panel. (See page 17)
Replace the cleaning pad. (See below)

● If the measures outlined above do not solve the problem, call Service.

Care of Copier

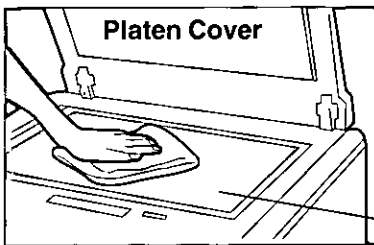

Platen Cover

Platen (glass)

As a rule, clean the Platen/Platen Cover weekly.

- ① Wipe marks off with cloth and neutral detergent.
 - Do not use benzine, thinners or other volatile cleaners.
- ② Wipe again with dry cloth.

Replacing the cleaning pad

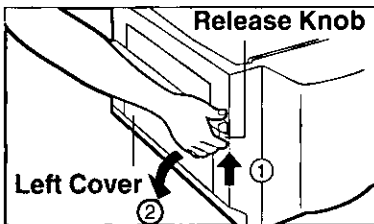

Release Knob

Left Cover

Cleaning Pad

When adding toner, replace the cleaning pad, too.

- ① Hold release knob.
- ② Open the left cover slowly.
- ③ Remove the cleaning pad.
- ④ Install the new cleaning pad.
 - The cleaning pad is supplied together with toner cartridge.
- ⑤ Close the left cover. Use both hands.

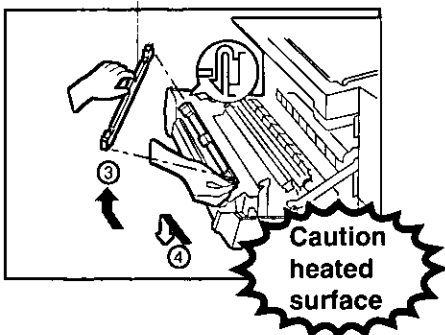

Caution heated surface

U.S.A. only

WARRANTY

"PANASONIC COMMUNICATIONS & SYSTEMS COMPANY MAKES NO WARRANTIES, GUARANTEES OR REPRESENTATIONS, EXPRESSED OR IMPLIED, TO CUSTOMER WITH RESPECT TO THIS PANASONIC COPIER, INCLUDING BUT NOT LIMITED TO, ANY IMPLIED WARRANTY OF MERCHANTABILITY OR FITNESS FOR A PARTICULAR PURPOSE
PANASONIC COMMUNICATIONS & SYSTEMS COMPANY ASSUMES NO RISK AND SHALL NOT BE SUBJECT TO LIABILITY FOR ANY DAMAGE, INCLUDING, BUT NOT LIMITED TO DIRECT, INDIRECT, SPECIAL, INCIDENTAL OR CONSEQUENTIAL DAMAGES OR LOSS OF PROFITS SUSTAINED BY THE CUSTOMER IN CONNECTION WITH THE USE OR APPLICATION OF THIS PANASONIC COPIER SEE YOUR DEALER FOR DETAILS OF DEALER'S WARRANTY "

For Service Call _____

Panasonic Office Products Company
A unit of Matsushita Electric Corporation of America
Plain Paper Copier Division
Two Panasonic Way, Secaucus, N J 07094

Panasonic Canada Incorporation
5770 Ambler Drive, Mississauga,
Ontario L4W 2T3